

Eccentric Screw Pumps ALL-OPTIFLOW SERIES AEB1F

Design IE in Block Design



Application

For handling liquid to highly viscous, neutral or aggressive, uncontaminated or abrasive liquids, liquids containing gases or which tend to froth, also containing fibers and solid matter

In waste water and waste water treatment engineering, chemical and petrochemical industry, paper and cellulose industry, soap and fats industry, paint and lacquer industry, food and beverage industry, plastics industry, ceramics industry, agriculture, sugar industry and in shipbuilding.

Operating

Self-priming, single-stage, rotary positive displacement pump. Conveying elements are the rotating eccentric screw (rotor) and the fixed stator. In the cross-sectional plane, both are in contact with one another at two points forming two sealing lines along the length of the conveying elements. The contents of the sealed chambers which are formed as the rotor turns, are displaced axially and with complete continuity from the suction to the discharge end of the pump. Despite rotor rotation, there is no turbulence. The constant chamber volume excludes squeezing, thus ensuring an extremely gentle low-pulsating delivery.

Design features

The pump and drive are held together by the bearing bracket to form a modular unit.

By means of external casing connecting screws (clamping screws), the discharge casing, stator and suction casing are interconnected. The suction casings are designed particularly favorable to flow. The pump sizes 403 to 5503 are supplied in cast iron and are provided with staggered holes for cleaning. The stator vulcanized into a tube is provided with external collars vulcanized to it on both sides, reliably sealing towards the suction casing and discharge casing and protecting the stator shell from corrosion.

The exchangeable shaft sealing housing or mechanical seal housing (subsequent conversion to another sealing variant is possible) are arranged between the suction casing and bearing bracket.

The torque of the drive is transmitted over the driving shaft and the joint shaft onto the rotor. On both sides, the joint shaft ends in liquid-tight encapsulated bolt joints, which are of particularly simple and sturdy design and easily absorb the eccentric movement of the rotor.

Shaft seal

By uncooled, cooled or heated stuffing box or by uncooled or cooled maintenance-free unbalanced, single or double-acting mechanical seal.

Material pairing and design are adapted to the respective operating conditions. For further data, refer to pages 4 and 5.

The stuffing box or mechanical seal housings of the various shaft sealing types are interchangeable within one size. The various mechanical seal housing parts form a modular construction system and, in case of conversion to a different mechanical seal design, can be easily combined with one another.

Installation spaces for mechanical seals according to DIN EN 12 756 (except for double mechanical seal).

For further information refer to pages 4, 5, 6 and 7.

Technical data

Deliveries, admissible speed ranges and required drive powers are to be taken from the performance graph on page 3 and/or the separate individual characteristic curves.

				AEB1F
Delivery	Q	l/min	up to	3800
Temperature of fluid pumped	t	°C ①	up to	100
Delivery pressure				
single-stage	Δp	bar	up to	6②
Pump outlet pressure	p_d	bar ③	up to	16
Attainable underpressure	p_s	bar ③	up to	0,95
Viscosity	η	mPa·s ②	up to	300.000
Admissible solids content			vol % ②	up to 60

The stated performance information serves only as an outline of performance of our products. For exact limits of application please refer to the quotation and acceptance of order.

Max. admissible grain sizes and fiber lengths

Size	103	203	403	553	703	
max. grain size	mm	3	3,8	5	6,8	6,8
max. fiber length	mm	42	48	60	79	79

Size	1003	1603	3003	5503	
max. grain size	mm	9,5	9,5	14	20
max. fiber length	mm	98	98	130	210

Increasing solids content and increasing grain size require a reduction of the pump speed:

- ① depending upon the fluid to be pumped and the elastomers employed
- ② depending on the pump size/design, speed and fluid to be pumped
- ③ depending on the direction of rotation, inlet pressure
- ④ 5 bar at sizes 3003, 5503

Bearings

The driving and the joint shaft are situated in the reinforced bearings of the electric motors, gear motors or control gear which also absorb the generated axial forces.

As all drives are only supplied with reinforced bearings it must be assured that the assigned pumps can be run at full capacity within their permissible application limits.

Drive

The drive can be provided by non-explosion-proof or explosion-proof three-phase motors, gear motors or control gear. For drive options see page 10. For technical data and dimensions, please refer to the separate sales documentation, data sheet 19-00-0000-111-3.

A considerable advantage is the fact that within a pump size the connection dimensions for all drive types are the same. This allows a later change to a different drive type or size.

Installation

AEB pumps may be installed horizontally or vertically, depending on the shaft seal. In case of vertical arrangement, "shaft shank downwards" is not admissible.

Exchangeability of components

The components of all eccentric screw pumps are of a modular design. This allows a simple and cost-effective spare parts management even if different series and designs of pumps are used.

Performance graph

For a rough selection of the pump size and speed as a function of the requested delivery and kind of fluid to be pumped.
 V_g "m" = available, mean sliding speed of the rotor in the stator.

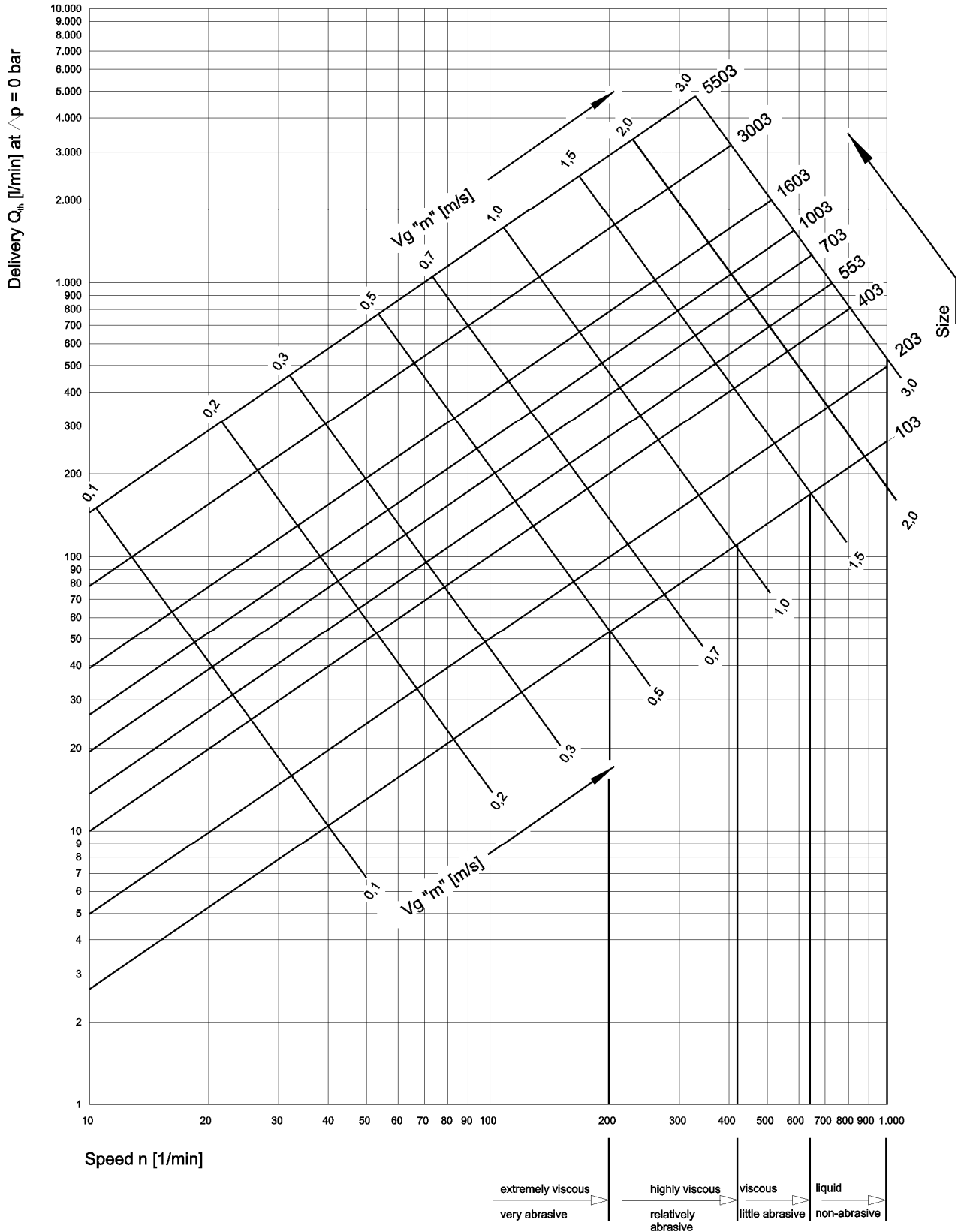

Sizes of the series AEB1F Data on the performance range not covered by AEB1F series are to be taken from the last page of this brochure and/or the individual brochures of the other series.
 For exact performance data, please refer to the individual characteristics.

Type code

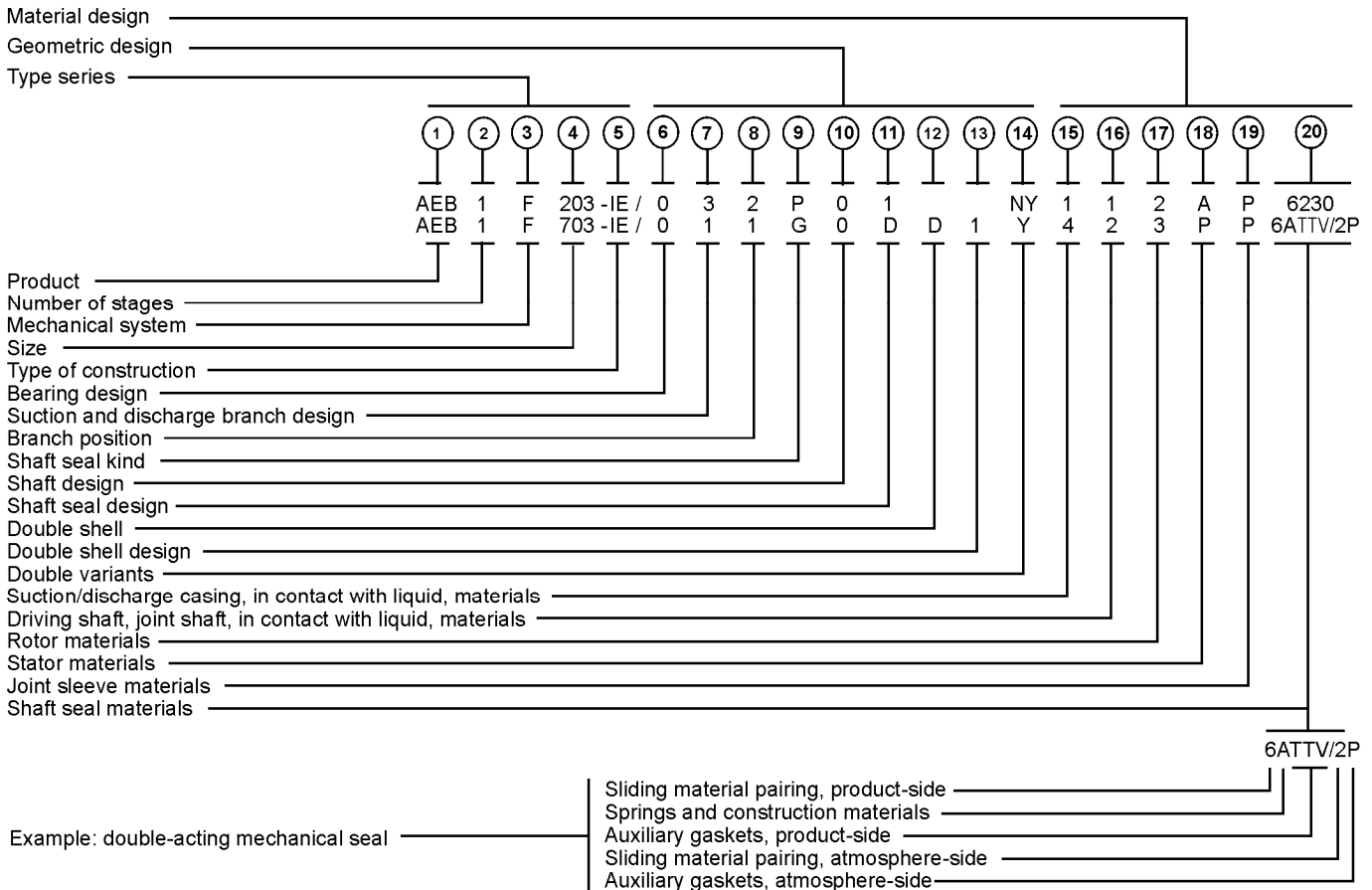

Explanations to the type code

Position in type code	Designation	Design
①	Product	ALLWEILER eccentric screw pumps
②	Number of stages	1 = single-stage up to delivery pressure $\Delta p = 6$ bar ($\Delta p = 4$ bar at sizes 3003, 5503)
③	Mechanical system	F = rated for delivery pressure $\Delta p = 6$ bar ($\Delta p = 4$ bar at sizes 3003, 5503)
④	Size	Possible sizes: 103, 203, 403, 553, 703, 1003, 1603, 3003, 5503. The numbers indicate the theoretic delivery in l/min with $n = 400$ 1/min and $\Delta p = 0$ bar
⑤	Design	IE = Industrial design with external bearing
⑥	Bearing design	0 = external bearing in drive unit
⑦	Suction and discharge branch design	1 = DIN-flanges 3 = ANSI-flanges X = Suction and/or discharge branch of special design] according to dimensional sheet, pages 8 and 9
⑧	Branch position	1, 2, 3, 4 – For arrangement please refer to the representation, page 8. Arrangement 3 is not possible for size 103.
⑨	Shaft seal type	P = Stuffing box or other non-mechanical shaft seal G = Mechanical seal (mechanical shaft seal)
⑩	Shaft design	0 = Shaft without shaft sleeve
⑪	Shaft seal design	Stuffing boxes P01 = Stuffing box of normal design (without sealing chamber ring / without flushing ring) P02 = Stuffing box with flushing ring P03 = Stuffing box with internal sealing chamber ring P04 = Stuffing box with external sealing chamber ring P0X = Non-mechanical shaft seal of special design

⑪	Shaft seal design (continued) X=design possible	Mechanical seal								
		For pump sizes								
		103	203	403	553	703	1003	1603	3003	5503
		Shaft diameter at location of shaft seal								
		25	30	35	43	43	53	53	60	75
		G0K = individual mechanical seal, DIN EN 12 756, design K, shape U								
		X	X	X	X	X	X	X	X	X
		G0N = as above, however design N								
		X	X	X	X	X	X	X	X	X
		G0S = individual mechanical seal, DIN EN 12 756, design K, shape U, rotating part with integrated locking device and pump-sided throttling ring								
X	X	X	X	X	X	X	X	X		
G0T = as above, however design N										
X	X	X	X	X	-	-	X	X		
G0Q = individual mechanical seal, DIN EN 12 756, design K, shape U with quench										
X	X	X	X	X	X	X	X	X		
G0D = double mechanical seal										
①	①	①	①	①	①	①	①	①		
G0X = mechanical seal of special design										
① design available on request										
⑫	Double shell	D = Double shell for heating/cooling, available in stainless steel only. Connections as threaded nipples for liquid media. Maximum heating/cooling pressure 6 bar, maximum heating temperature + 100°C, maximum cooling temperature -40°C								
⑬	Double shell design	1 = Suction case with double shell 2 = Stuffing box for P01 with double shell 12 = Suction and shaft sealing housing P01 with double shell X = Special design for other double shells								
⑭	Design variants	Stator with uneven elastomer wall thickness (all qualities)								
		N M H T	} Rotor with temperature play as a function of the temperature of the fluid pumped							
		Y = Rotor ductile hard chromium-plated				W = Winding protection on joint shaft				
		Z = Rotor metallically coated				X = Other designs				
		S = Worm on joint shaft								
⑮	Suction and discharge casing in contact with fluid, materials	1 = gray cast iron EN-GJL-250								
		3 = gray cast iron EN-GJL-250, inside H-rubberized								
		4 = 1.4408								
		A = 1.4462								
		X = Special materials								
⑯	Driving shaft, joint shaft casing in contact with fluid, materials	1 = 1.4021/1.1191								
		2 = 1.4301/1.4571/1.4462								
		4 = 1.4571/1.4462								
		A = 1.4462								
		X = Special materials, i.e. also for articulated components								
⑰	Rotor materials	2 = 1.4301			4 = 1.4571			A = 1.4462		
		3 = 1.2436/1.2379			X = Special materials, e.g. other metals, plastic materials					
⑱	Stator materials	PA = Acrylonitrile-butadiene rubbers (NBR)			P = Acrylonitrile-butadiene rubbers (NBR)			A = ALLDUR		
		HP = Acrylonitrile-butadiene rubbers, hydrated (HNBR)			E = EPDM					
		Y = Chlorosulfonated polyethylene (CSM)			X = Special materials					
⑲	Joint sleeve materials	P = Acrylonitrile-butadiene rubbers (NBR)			Y = Chlorosulfonated polyethylene (CSM)			X = Special materials		
		N = Polychloroprene (N)			B = Butyl caoutchouc					
⑳	Shaft seal materials	Stuffing box: 5846 = Ramie fiber with PTFE impregnation, asbestos-free 6426 = Aramid endless fiber with PTFE impregnation, asbestos-free 6230 = Graphite-incorporated PTFE with sliding means, asbestos-free								
		Mechanical seal:								
		Sliding material pairing			Spring and construction materials			Auxilliary gaskets		
		1st point for single gasket 1st + 4th point for double gasket			2nd point			3rd point for single gasket 3rd + 5th points for double gasket		
		2 = CrMo cast iron/hard carbon			A = 1.4300			P = Acrylonitrile-butadiene rubbers (NBR) ① double		
		4 = Ceramics/hard carbon			F = 1.4571			E = EP caoutchouc PTFE-coated		
		5 = Hard metal/hard metal, highly wear-resistant			L = Hastelloy B			S = Silicon caoutchouc		
6 = Silicon carbide/silicon carbide highly wear-resistant, corrosion-resistant			M = Hastelloy C4			N = Polychloroprene (N)				
7 = Silicon carbide/silicon carbide highly wear-resistant, highly corrosion-resistant			X = Special materials			V = Fluoroelastomer (FPM)				
X = Special materials						TTE = EP caoutchouc ①				
						TTV = Fluoroelastomer (FPM) ①				
						TTS = Silicon caoutchouc ①				
						X = Special materials				

Sectional drawing and components list

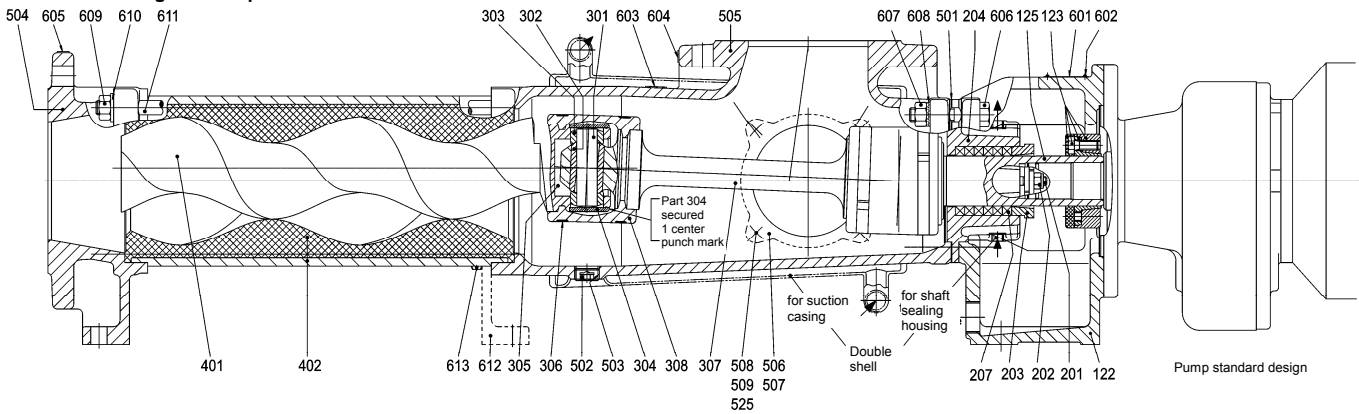

Bearing 0: External bearing in drive unit.
Shaft seal P01: Due to particularly great packing length, versatile, admissible pressure at the shaft seal $p = -0.7$ to 16 bar.

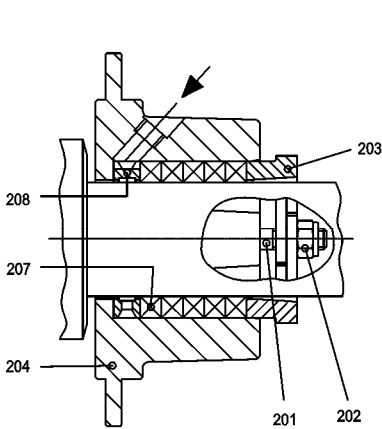

P02 Stuffing box with flushing ring

To be employed for very abrasive fluids pumped with external flushing.
 $p = -0,7$ to 12 bar

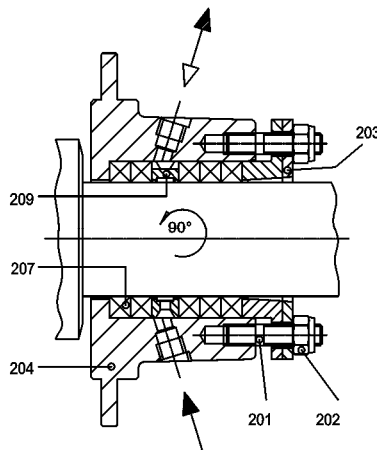

P03 Stuffing box with internal sealing chamber ring.

To be employed for pure fluids with internal sealing or for abrasive fluids with external sealing.
 $p = -0,8$ to 6,0 bar

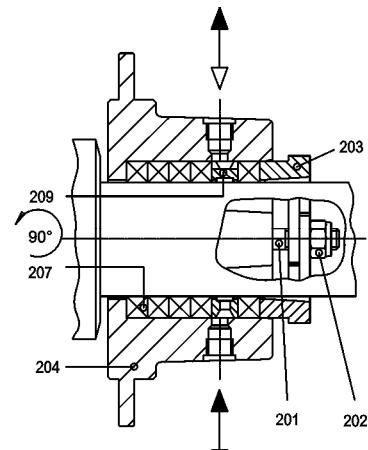

P04 Stuffing box with external sealing chamber ring.

To be employed in case of incompatibility of the external sealing liquid with the fluid pumped or if air inlet is to be avoided.
 $p = -0,9$ to 12 bar

Part-No.	Name
122	Bearing bracket
123	Tensioning set
125	Driving shaft
201	Stud bolt
202	Self-locking nut
203	Gland half
204	Shaft sealing housing
207	Stuffing box
208	Flushing ring
209	Sealing chamber ring
212	Screw plug
213	Joint tape
214	Mechanical seal housing

Part-No.	Name
215	Mechanical seal cover
218	O-ring
219	Mechanical seal
220	Locking pin
232	Shaft seal ring
234	Throttling ring
235	O-ring
236	Locking pin
245	Hexagon screw
251	Sealing compound
301	Joint bolt
302	Joint bush
303	Bush for joint bolt

Part-No.	Name
304	Joint sleeve
305	Joint lubricant
306	Joint clamp
307	Joint shaft
308	Joint collar
401	Rotor
402	Stator
403	Stator gasket delivery-side
404	Stator gasket suction-side
501	Gasket for suction casing
502	Screw plug
503	Joint tape
504	Delivery casing

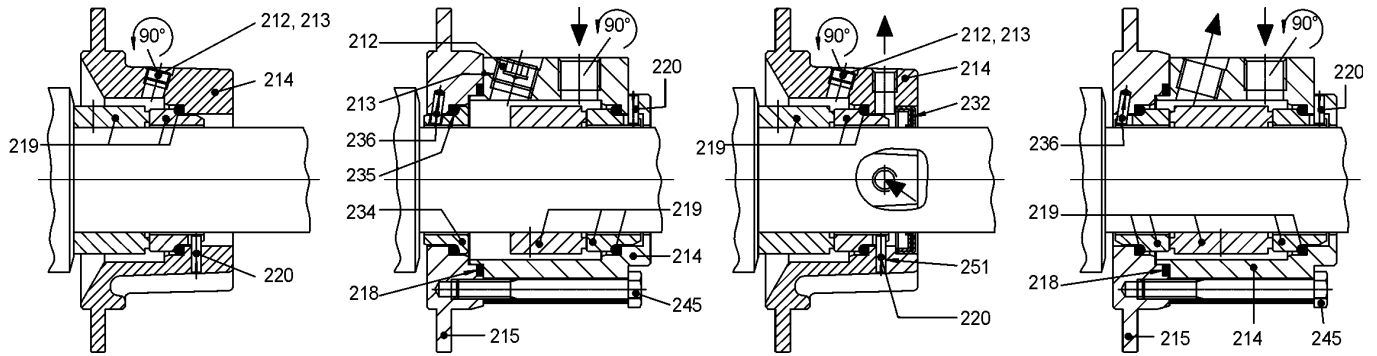

G0K/G0N Single mechanical seal, DIN EN 12756, K/N design, U shape. For employment, please inquire, p = -0,5 to 16 bar

G0S/G0T Single mechanical seal, DIN EN 12756, K/N design, U shape, Integrated locking device with flushing liquid connection and pump-side throttling ring. For employment, please inquire, p = -0,5 to 16 bar

G0Q Single mechanical seal, DIN EN 12756, K design, U shape with quench. For employment, please inquire, p = -0,5 to 16 bar

G0D Double mechanical seal with sealing liquid connection. For employment, please inquire, p = -0,95 to 16 bar

Part-No.	Name
505	Suction casing
506	Suction casing cover
507	Gasket
508	Stud bolt
509	Hexagon nut
525	Washer
601	Type plate
602	Round head grooved pin
603	Information plate commissioning
604	Information plate suction
605	Information plate pressure
606	Hexagon screw/stud bolt

Part-No.	Name
607	Hexagon nut
608	Fan-type lock washer
609	Hexagon nut
610	Washer
611	Clamp bolt
612	Support
613	Hexagon screw
627	Information plate Physical hazard

① Not possible for size 103

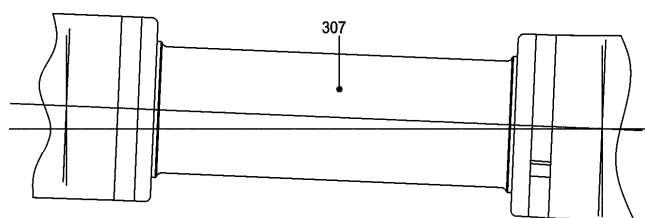

Winding protection on joint shaft

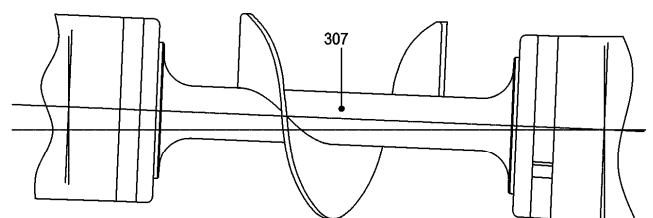

Worm on joint shaft

Pump dimensions, auxiliary connections, possible branch positions, weights
Suction casing with flange connection

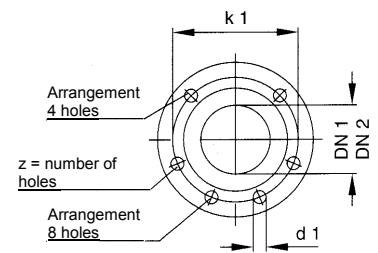
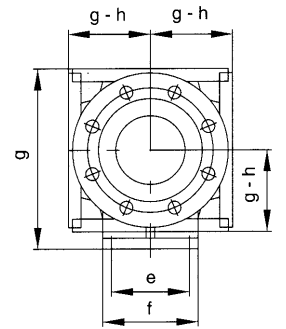
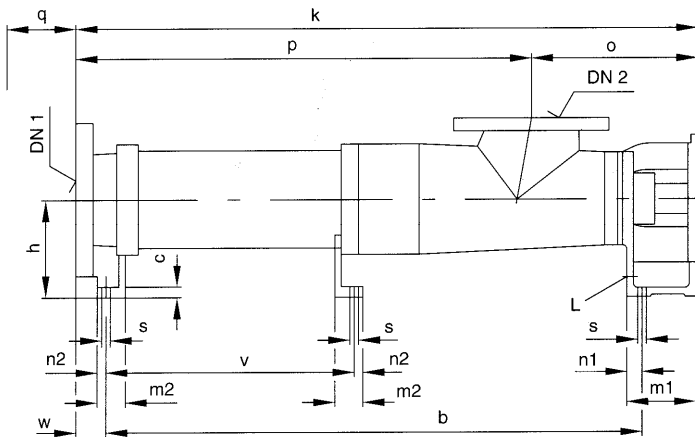

Dimensions in mm, nominal width of ANSI-flanges (DN) in inches.
 Subject to alteration.

Sense of rotation: Normally counter-clockwise as seen from the driving side with DN₁ = discharge branch, DN₂ = suction branch, change of rotation possible, then DN₁ = suction branch, DN₂ = discharge branch

Series Size	Pump dimensions														max. mass kg
	b	c	e	f	h	m ₁	m ₂	n ₁	n ₂	o	① q	s	L	v	
AEB1F 0103-IE	585	10	75	95	90	84	30	19	11	167	280	9	Rp 3/8	-	26
AEB1F 0203-IE	711	10	85	105	100	93	30	19	11	192	365	9	Rp 3/8	-	36
AEB1F 0403-IE	897	13	100	125	125	106	38	25	13	227	470	11,5	Rp 1/2	-	58
AEB1F 0553-IE	923	15	114	140	140	110	40	26	14	252	430	14	Rp 3/4	-	78
AEB1F 0703-IE	1075	15	114	140	140	110	40	26	14	252	580	14	Rp 3/4	-	91
AEB1F 1003-IE	1070,5	16	132	168	160	128	50	31	19	304	490	18	Rp 3/4	-	125
AEB1F 1603-IE	1358,5	16	132	168	160	128	50	31	19	304	780	18	Rp 3/4	-	153
AEB1F 3003-IE	1679,5	16	164	200	180	131	50	31	19	330	980	18	Rp 3/4	1079	252
AEB1F 5503-IE	2041,5	21	200	245	225	153	63	40	23	407,5	1195	22	Rp 1	1313	415

① Stator dismantling dimension

Possible branch positions as seen from the drive

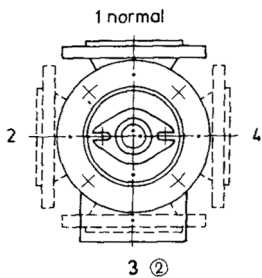

② not for size 103

Flange dimensions

DIN EN 1092, PN 16 ⑤				ANSI B16.1/16.5, Class 125/150 ④			
DN ₁ /DN ₂	k ₁	d ₁	z	DN ₁ /DN ₂	k ₁	d ₁	z
50	125	18	4	2	120,6	19	4
65	145	18	4	2 1/2	139,7	19	4
80	160	18	8	3	152,4	19	4
100	180	18	8	4	190,5	19	8
125	210	18	8	5	215,9	22,2	8
150	240	22	8	6	241,3	22,2	8
200	295	22	12	8	298,4	22,2	8

Series Size	Connection dimensions for suction and discharge branch																	
	Flange DIN EN 1092, PN 16 ③						Flange ANSI B16.1, Class 125 ④						Flange ANSI B16.5, Class 150 ④					
	DN ₁	③ DN ₂	③ k	③ p	③ w	③ g	DN ₁	DN ₂	③ k	③ p	③ w	③ g	DN ₁	DN ₂	k	p	w	g
AEB1F 0103-IE	50	50	696	529	43	175	2	2	692	525	39	171	2	2	696	529	43	175
AEB1F 0203-IE	65	65	834	642	46	190	2 ½	2 ½	833	641	45	189	2 ½	2 ½	838	646	50	194
AEB1F 0403-IE	80	80	1026	799	45	230	3	3	1024	797	43	228	3	3	1029	802	48	233
AEB1F 0553-IE	100	100	1054	802	43,5	260	4	4	1056	804	45,5	262	4	4	1056	804	45,5	262
AEB1F 0703-IE	100	100	1206	954	43,5	260	4	4	1208	956	45,5	262	4	4	1208	956	45,5	262
AEB1F 1003-IE	125	125	1216	912	44	300	5	5	1216	912	44	300	5	5	1216	912	44	300
AEB1F 1603-IE	125	125	1504	1200	44	300	5	5	1504	1200	44	300	5	5	1504	1200	44	300
AEB1F 3003-IE	150	150	1842	1512	59	350	6	6	1842	1512	59	350	6	6	1842	1512	59	350
AEB1F 5503-IE	200	200	2222,5	1815	64	425	8	8	2222,5	1815	64	425	8	8	2222,5	1815	64	425

③ for rubber-coating + 3 mm

④ Connecting dimensions acc. DIN EN 1092, up to DN100 raised face form B, greater than DN100 raised form A

④ sealing surface: stock

Arrangement of auxiliary connections for shaft seals

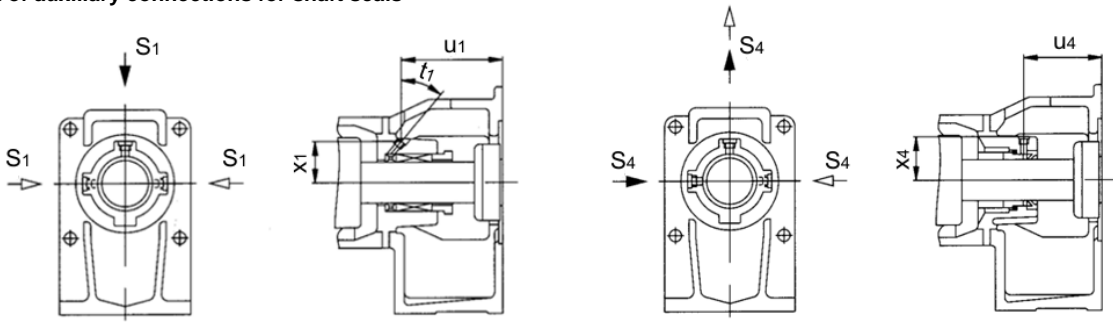

P02 with flushing ring

G0Q with quench connection

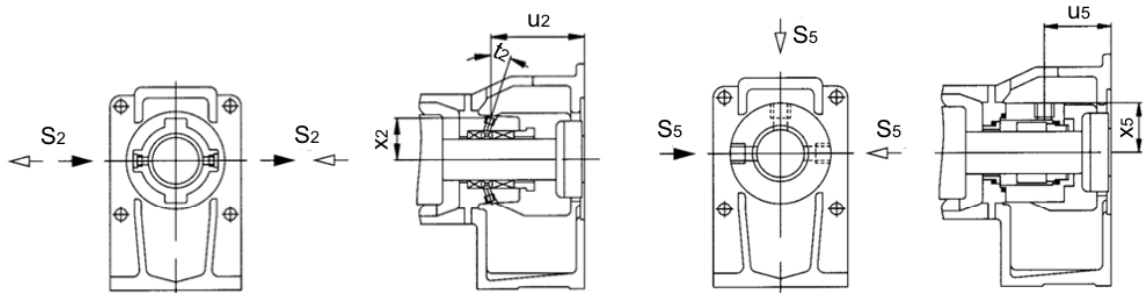

P03 with internal sealing chamber ring

G0S/G0T with flushing connection

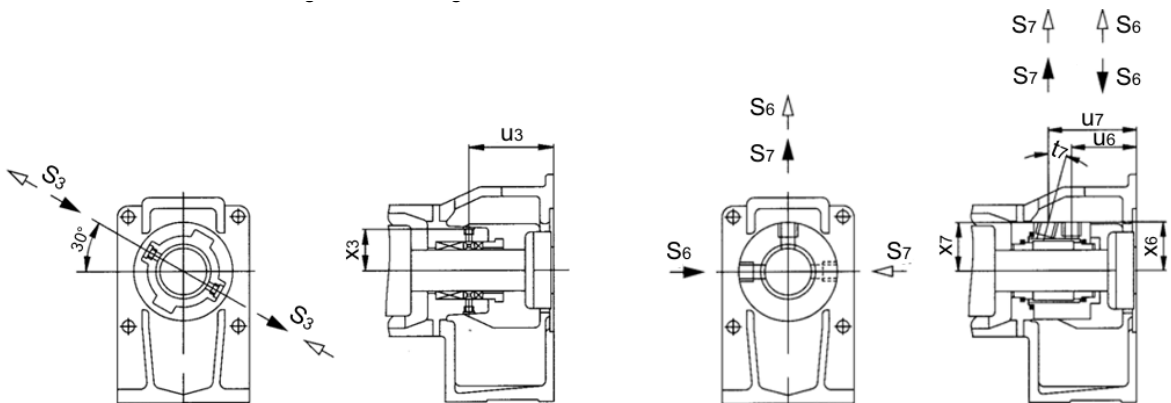

P04 with external sealing chamber ring

G0D with sealing connection

Series Size	Connection dimensions for auxiliary connections for shaft seals										
	P02 with flushing ring				P03 with internal sealing chamber ring				P04 with external sealing chamber ring		
	S ₁ ⊕	u ₁	x ₁	t ₁	S ₂ ⊕	u ₂	x ₂	t ₂	S ₃ ⊕	u ₃	x ₃
AEB 1F 103-IE	M 8 x 1	84	28	42°	M 8 x 1	77	30	20°	M 8 x 1	69	30,5
AEB 1F 203-IE	M 8 x 1	93	31,5	40°	M 8 x 1	87	32	20°	M 8 x 1	78,5	33,5
AEB 1F 403-IE	Rp ½	104,5	38	42°	Rp ½	97	40	17°	Rp ½	85	39,5
AEB 1F 553-IE	Rp ½	109,5	42	42°	Rp ½	102	44	17°	Rp ½	91,5	43,5
AEB 1F 703-IE	Rp ½	109,5	42	42°	Rp ½	102	44	17°	Rp ½	91,5	43,5
AEB 1F 1003-IE	Rp ½	128,5	52	42°	Rp ½	119,5	54	17°	Rp ½	105	54,5
AEB 1F 1603-IE	Rp ½	128,5	52	42°	Rp ½	119,5	54	17°	Rp ½	105	54,5
AEB 1F 3003-IE	Rp ½	133	56	35°	Rp ½	122,5	57	13°	Rp ½	106	58
AEB 1F 5503-IE	Rp ¼	155	67	35°	Rp ¼	142	68,5	13°	Rp ¼	122	69,5

Series Size	Connection dimensions for auxiliary connections for shaft seals												
	G0S/G0T with flushing connection			G0Q with quench connection			G0D with sealing connection						
	S ₅ ⊕	u ₅	x ₅	S ₄ ⊕	u ₄	x ₄	S ₆ ⊕	S ₇ ⊕	u ₆	u ₇	x ₆	x ₇	t ₇
AEB 1F 103-IE	Rp ¼	46,5	34	Rp ½	56	30,5	Rp ¼	Rp ¼	46,5	71,5	34	33	15°
AEB 1F 203-IE	Rp ¼	55	38	Rp ½	63,5	30,5	Rp ¼	Rp ¼	55	79	38	36,5	15°
AEB 1F 403-IE	Rp ¼	69,5	41,5	Rp ½	74	33,5	Rp ¼	Rp ¼	69,5	95	41,5	40	15°
AEB 1F 553-IE	Rp ⅜	71,5	48,5	Rp ½	79	41	Rp ⅜	Rp ⅜	71,5	96,5	48,5	47	15°
AEB 1F 703-IE	Rp ⅜	71,5	48,5	Rp ½	79	41	Rp ⅜	Rp ⅜	71,5	96,5	48,5	47	15°
AEB 1F 1003-IE	Rp ⅜	92,5	56	Rp ½	99,5	54	Rp ⅜	Rp ⅜	92,5	118	56	53,5	20°
AEB 1F 1603-IE	Rp ⅜	92,5	56	Rp ½	99,5	54	Rp ⅜	Rp ⅜	92,5	118	56	53,5	20°
AEB 1F 3003-IE	Rp ⅜	80,5	61	Rp ½	99	57,5	Rp ⅜	Rp ⅜	80,5	121	61	58,5	20°
AEB 1F 5503-IE	Rp ⅜	103	71,5	Rp ¼	106,5	68,5	Rp ⅜	Rp ⅜	103	145	71,5	69	22°

⊕ Threaded connection DIN 3852, shape Z

- ▶ Standard supply
- ▷ Possible supply. In this case, the sealing Housing must be turned for designs P02, G0S, G0T, G0Q, G0D.

Drive options

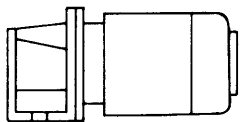

AEB-IE with electric motor

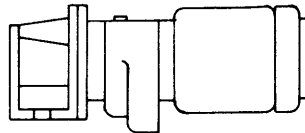

AEB-IE with gear motor

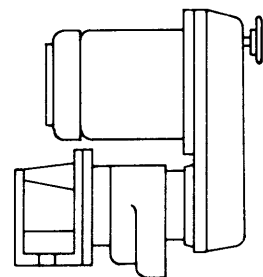

AEB-IE with infinitely variable gear

Range of eccentric screw pumps	Series	Number of stages	Max. capacity at $\Delta p = 0$ bar		Max. discharge pressure bar	Max. viscosity mPa·s
			m ³ /h	l/min		
	AE1F	1	228	3800	6	300.000
	AEB1F	1	228	3800	6	300.000
	AE1L-ID	1	162	2700	4	200.000
	AE.E-ID	1,2	450	7500	10	300.000
	AE.N-ID	1,2	290	4850	16	270.000
	AE.H-ID	2,4	174	2900	24	270.000
	AEB1L-IE	1	162	2700	4	200.000
	AEB.E-IE	1,2	174	2900	6	300.000
	AEB.N-IE	1,2	111	1850	12	270.000
	AEB4H-IE	4	12	200	24	270.000
	AE.N...-RG	1,2,4	30	500	20	1.000.000
	TECFLOW	1	162	2700	4	200.000
	SEZP	1,2	21	350	10	1.000.000
	SNZP	1,2	45	750	12	1.000.000
	SNZBP	1,2	45	750	12	1.000.000
	SSP	1,2	48	800	12	150.000
	SSBP	1,2	48	800	12	150.000
	SETP ①	1,2	140	2350	10	300.000
	SETBP	1,2	40	670	10	150.000
	SEFBP	1	40	670	6	150.000
	SMP	1	40	670	6	150.000
	SMP2	1	5,5	92	6	11.500
	AFP	1	2,8	47	6	50.000
	ANP	2	2,5	42	12	20.000
	ANBP	2	2,5	42	12	20.000
	ASP	2	2,5	42	12	20.000
	ASBP	2	2,5	42	12	20.000
	ADP	3	0,6	10	12	20.000
	ADBP	3	0,6	10	12	20.000
	ACNP	1,2	29	480	12	150.000
	ACNBP	1,2	29	480	12	150.000

① available in special version for higher pressure

Peristaltic range	Series	Max. capacity		Max. discharge pressure bar	Max. viscosity mPa·s
		m ³ /h	l/min		
	ASL	2,4	40	4	100.000
	ASH	60	1000	15	100.000

Macerator range	Series	Max. throughput m ³ /h	Static pressure head	
			m	
	AM ... S-1	80 at 3 % TS	3	
	ABM S-1	80 at 3 % TS	3	
	AM ... I-1	160 at 3 % TS	-	
	ABM I-1	80 at 3 % TS	-	

Accessories

<u>Pump:</u>	Stator setting devices, electrical heaters, bridge breakers.
<u>Drivers:</u>	Electric motors, geared motors, variable speed transmissions, reduction gearboxes, internal combustion engines, pneumatic and hydraulic drives.
<u>Transmission components:</u>	Couplings, V-belt transmissions, toothed belt transmissions, other types of transmission.
<u>Base plates:</u>	Standard and special versions, wheeled trolleys, mounting flanges.
<u>Safety arrangements:</u>	Bypass lines with safety or regulating valves, systems to guard against dry running (conductive, capacitive, thermal etc.).
<u>Other accessories:</u>	Electrical, hydraulic and pneumatic control arrangements, filter systems, metering equipment, seal liquid and circulating systems for shaft seals, valves, flanges, flexible pipes.

Subject to technical alterations.